

»value line« Series

For reducing the exhaust noise generated by pneumatic equipment.

Operating pressure: Max. 10 bar
 Operating temperature: -10 °C to +200 °C
 Noise level at 6 bar: 80 ~ 90 dB (A)

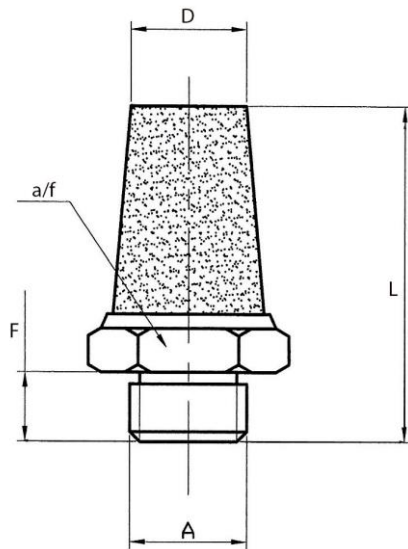

567-4-ME

Silencer, sintered bronze, with brass hexagon nut and brass thread

Art. No.	Type No.	Thread A	D mm	L mm	F mm	a/f mm	Flow rate l/min	Pore size µm
116281	567-0/ME	M5	4	20.8 +/-0.5	5.0	9	356	50
116282	567-1/ME	G 1/8	8	22.8 +/-0.5	5.5	13	1058	50
116283	567-2/ME	G 1/4	10	33.5 +/-0.5	7.0	17	1522	50
116284	567-3/ME	G 3/8	14	41.7 +/-0.5	9.0	22	3069	50
116285	567-4/ME	G 1/2	18	48.5 +/-1.0	10.0	24	3108	50

Sintered bronze silencers

Art. No. 116281 to 116285
 Art. No. 116286 to 116289
 Art. No. 116290 to 116294

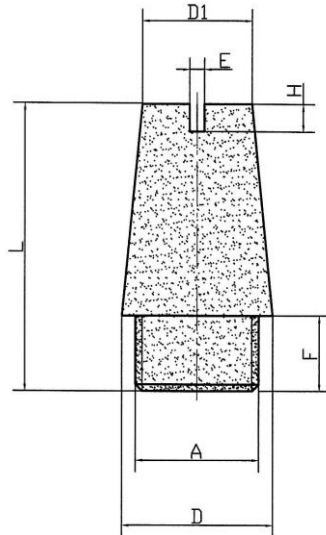

568-4-E

Silencer, sintered bronze, slotted

Art. No.	Type No.	Thread A	F mm	D mm	D1 mm	E mm	H mm	L mm	Flow rate l/min	Pore size µm
116286	568-1-E	G 1/8	5.5 +/-0.5	11.0 +/-0.3	8.0 +/-0.3	1.5 +/-0.2	2.0 +/-0.5	21 +/-0.6	489	50
116287	568-2-E	G 1/4	8.5 +/-0.5	14.0 +/-0.3	10.0 +/-0.3	1.5 +/-0.2	2.0 +/-0.5	27 +/-0.6	650	50
116288	568-3-E	G 3/8	11.0 +/-0.5	18.0 +/-0.3	15.0 +/-0.3	2.0 +/-0.2	2.0 +/-0.5	36 +/-0.6	1980	50
116289	568-4-E	G 1/2	11.0 +/-0.5	24.0 +/-0.3	19.0 +/-0.3	2.0 +/-0.2	3.0 +/-0.5	44 +/-0.6	2150	50

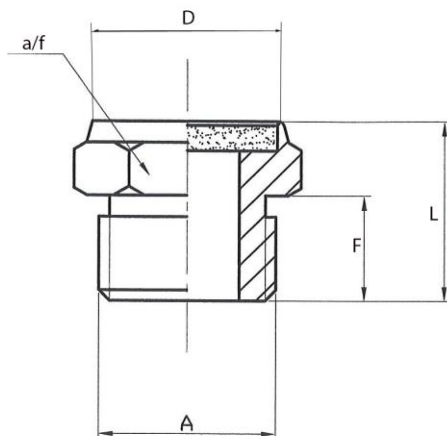

569-1-E

Silencer, sintered bronze, flat design with brass hexagon nut and brass thread

Art. No.	Type No.	Thread A	L mm	F mm	D mm	a/f mm	Flow rate l/min	Pore size µm
116290	569-0-E	M5	7.6	4.0	6.0	8	217	70-90
116291	569-1-E	G 1/8	10.5	5.5	11.0	13	414	100-120
116292	569-2-E	G 1/4	13.5	7.0	13.0	17	533	100-120
116293	569-3-E	G 3/8	16.0	7.5	17.0	22	610	100-120
116294	569-4-E	G 1/2	18.0	9.5	20.0	24	1134	100-120

- The use of silencers does not automatically reduce exhaust noise to a safe level. The need for other noise-reducing measures, such as hearing protection, must be assessed as well.

- Uses and applications are the responsibility of the user. However, it is necessary to carry out appropriate tests before use in order to convince yourself of the desired function under the respective conditions. All further claims, in particular liability for consequential damages, are excluded in principle.